

WAS4732D

MIC/GND Cross-point Switch for EU/US Headphone Compatible Application

Descriptions

The WAS4732D is a 2x2 cross-point switch that is used to interchange the Ground and MIC connections on a headphone connector. The Ground switch has an ultra-low Ron of 0.1 Ω (typical) to minimize voltage drop across it, preventing undesired increase in headphone ground reference voltage. the switch state is controlled via the SEL input. When SEL=High, GND is connected to COM2 and MIC is connected to COM1; When SEL=Low, GND is connected to COM1 and MIC is connected to COM2. An internal pull-down 2MΩ resistor on SEL input sets the default state of the switch.

The WAS4732D is available in DFN2x2-6L package. Standard product is Pb-Free and halogen-Free.

Features

- Supply voltage : 2.3 ~ 5.0V
- ultra-low Ron for GND Switch : 100mΩ
- low Ron for MIC Switch : 4.5 Ω
- Break-Before-Make Switching
- Low quiescent current over an Expanded Control Input Range
- ESD Rating (HBM JEDEC: JESD22-A114)
 - ◆ IO to GND : ±8KV
 - ◆ Power to GND : ±5KV
- Replace TS3A26746E with compatible PCB Layout

Applications

- Cell phone
- Tablet
- Others Music Players

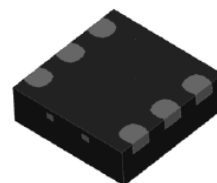

DFN2x2-6L

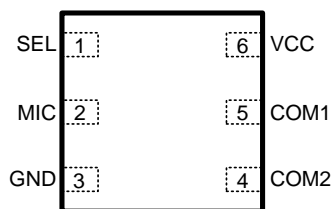

Pin configuration (Top view)

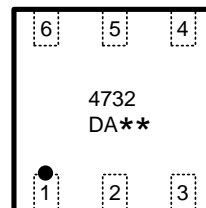

4732 = Device code
****** = Year & Week (A-Z)

Marking

Order information

Device	Package	Shipping
WAS4732D-6/TR	DFN2x2-6L	3000/Reel&Tape

Pin descriptions

Pin Number	Symbol	Descriptions
1	SEL	Logic Control
2	MIC	MIC Port
3	GND	Ground
4,5	COM _x	Audio Signal Port
6	VCC	Positive Power Supply

Function descriptions

Logic Input (SEL)	Function
0	GND is connected to COM1 and MIC is connected to COM2
1	GND is connected to COM2 and MIC is connected to COM1

Functional Block

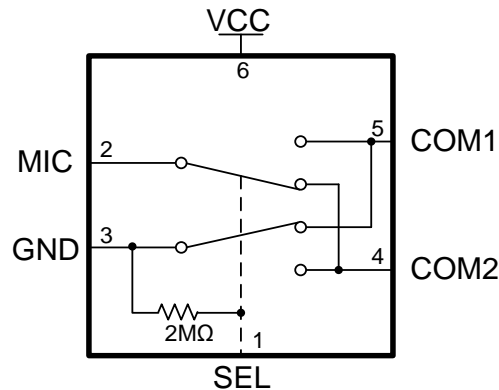

Typical Applications

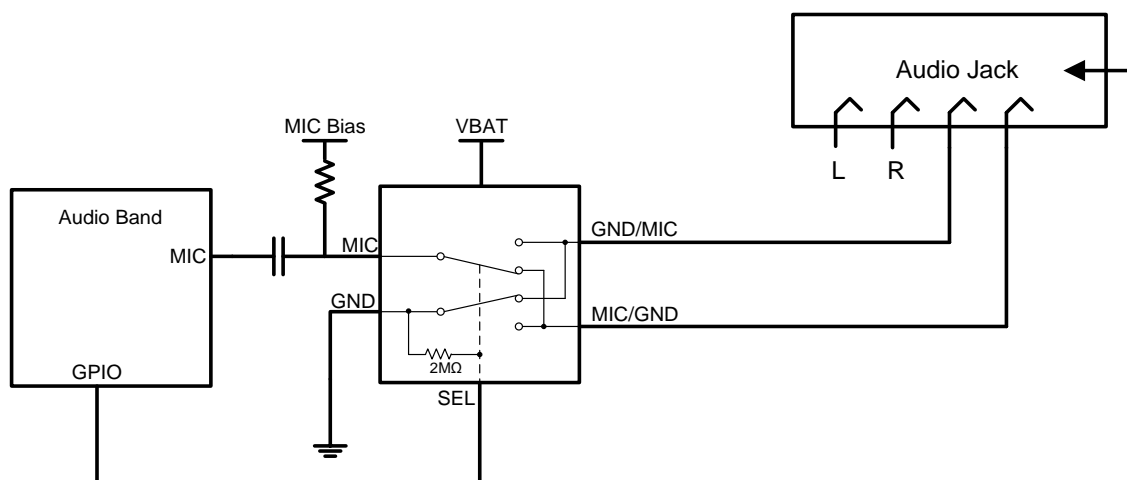

Absolute Maximum Ratings ⁽¹⁾

Parameter	Symbol	Value	Unit
Supply Voltage	V_{CC}	-0.3 ~ 6.5	V
Control Input Voltage	V_{INx}	-0.3 ~ 6.5	V
DC Input Voltage ⁽²⁾	V_{INPUT}	-0.3 ~ 6.5	V
Continuous Current through COMx		±100	mA
Storage Temperature Range	T_{STG}	-65 ~ 150	°C
Junction Temperature under Bias	T_J	150	°C
Lead Temperature (Soldering, 10 seconds)	T_L	260	°C
Power Dissipation	P_D	250	mW

Recommend operating ratings ⁽³⁾

Parameter	Symbol	Value	Unit
Supply Voltage Operating	V_{CC}	2.3 ~ 5.0	V
Control Input Voltage	V_{IN}	0.0 ~ V_{CC}	V
Input Signal Voltage	V_{IS}	0.0 ~ V_{CC}	V
Operating Temperature	T_A	-40 ~ 85	°C
Input Raise and Fall Time(Control Input $V_{CC}=2.3\sim 3.6V$)	t_r, t_f	0 ~ 10	ns/V
Thermal Resistance	$R_{\theta JA}$	350	°C/W

Note:

1. "Absolute Maximum Ratings" may cause permanent damage to the device. This is a stress only rating and operation of the device at these or any other conditions beyond those indicated in the operational sections of this specification is not implied.
2. The input and output negative voltage ratings may be exceeded if the input and output diode current ratings are observed.
3. Control input must be held high or Low, it must not float.

DC Electronics Characteristics (Ta=25°C, VCC=3.6V, unless otherwise noted)

Parameter	Symbol	Conditions	Min.	Typ.	Max.	Unit
Input logic high level	V _{IH}	VCC: 3.0 ~ 4.5	1.6			V
		VCC: 2.3 ~ 3.0	1.4			V
Input logic low level	V _{IL}	VCC: 3.0 ~ 4.5			0.6	V
		VCC: 2.3 ~ 3.0			0.4	V
Supply quiescent current	I _{CC}	I _{OUT} =0, V _{IN} =0 or V _{IN} =VCC			1.0	uA
Increase in I _{CC} per input	I _{CCT}	I _{OUT} =0, VCC=4.5 V _{IN} >1.8 or V _{IN} <0.5			2.0	uA
SEL Input leakage current	I _{IN}	V _{SEL} =VCC			2.0	uA
Off state switch leakage current	I _{OFF}				±1.0	uA
On state switch leakage current	I _{ON}				±1.0	uA
GND path On-Resistance	R _{ON1}	VCC=2.8V, V _{SW} = 0 ~ 1V I _{OUT} =32mA			0.1	Ω
GND path On-Resistance match	Δ R _{ON1}	VCC =2.8V, V _{SW} = 0 ~ 1V I _{OUT} =32mA			0.02	Ω
GND path On-Resistance flatness	R _{FLAT1(ON)}	VCC=2.8V, V _{SW} = 0 ~ 1V I _{OUT} =32mA			0.02	Ω
MIC path On-Resistance	R _{ON2}	VCC=2.8V, V _{SW} = 0 ~1.8V I _{OUT} =32mA			4.5	Ω
MIC path On-Resistance match	Δ R _{ON2}	VCC =2.8V, V _{SW} = 0 ~VCC I _{OUT} =32mA			0.5	Ω
MIC path On-Resistance flatness	R _{FLAT2(ON)}	VCC=2.8V, V _{SW} = 0 ~1.8V I _{OUT} =32mA			1.5	Ω

AC Electronics Characteristics (Ta=25°C, VCC=3.6V, unless otherwise noted)

Parameter	Symbol	Conditions	Min.	Typ.	Max.	Unit
Turn-On Time	T _{ON}	V _{IS} =1.5V, C _L =35pF, R _L =50Ω		150		ns
Turn-Off Time	T _{OFF}	V _{IS} =1.5V, C _L =35pF, R _L =50Ω		150		ns
Break-Before-Make time	T _{BBM}	V _{IS} =1.5V, C _L =35pF, R _L =50Ω		800		ns
-3dB Bandwidth	BW	R _L =50Ω, C _L =0pF		30		MHz
Off isolation	OIRR	F=1KHz, R _L =50Ω		-50		dB
		F=10KHz, R _L =50Ω		-50		dB
Crosstalk	Xtalk	F=1KHz, R _L =50Ω		-50		dB
		F=10KHz, R _L =50Ω		-50		dB
Total Harmonic Distortion (MIC)	THD	F=20Hz to 20KHz R _L =1KΩ, V _{IS} =30mVpp		0.01		%

Capacitance (Ta=25°C unless otherwise noted)

Parameter	Symbol	Conditions	Min.	Typ.	Max.	Unit
Off capacitance	C _{OFF}	F=100KHz, VCC=3.3		100		pF
On capacitance	C _{ON}	F=100KHz, VCC=3.3		140		pF

Test Circuits

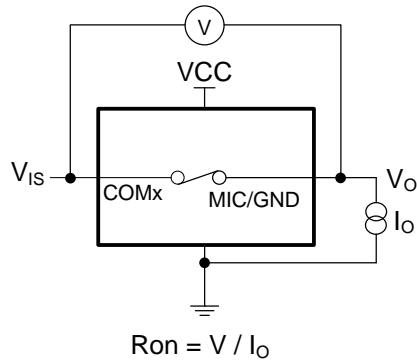

ON-Resistance (R_{ON})

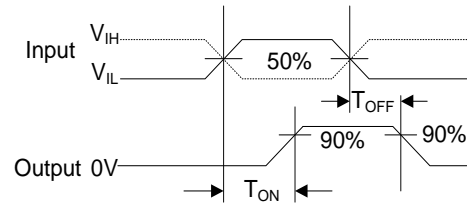

ON/OFF Time Waveforms (T_{ON} / T_{OFF})

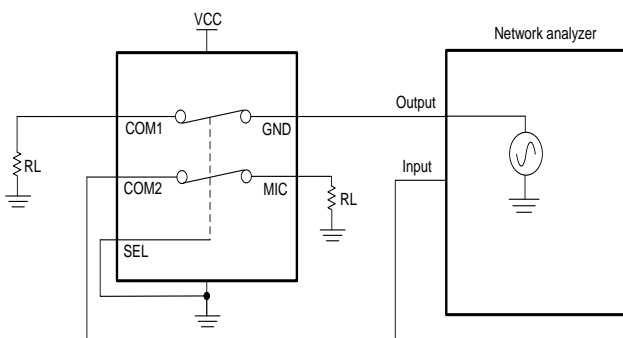

Crosstalk (Xtalk)

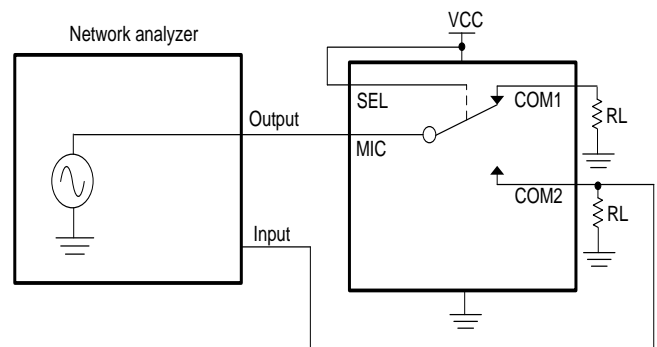

Off isolation (OIRR)

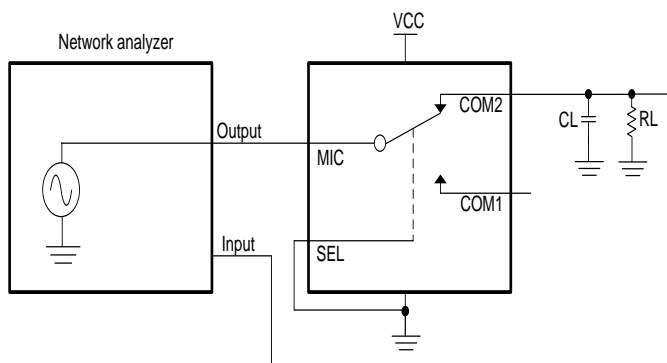

Bandwidth (BW)

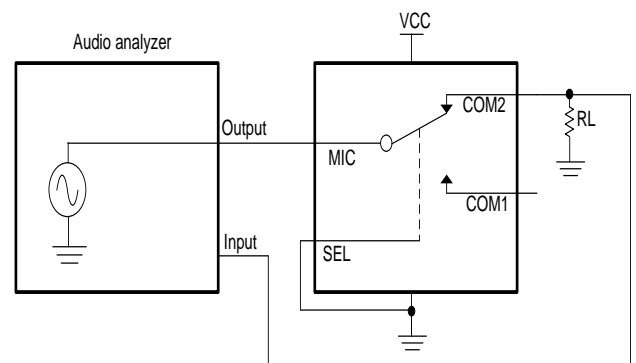

THD+N

Package Information

DFN2x2-6L

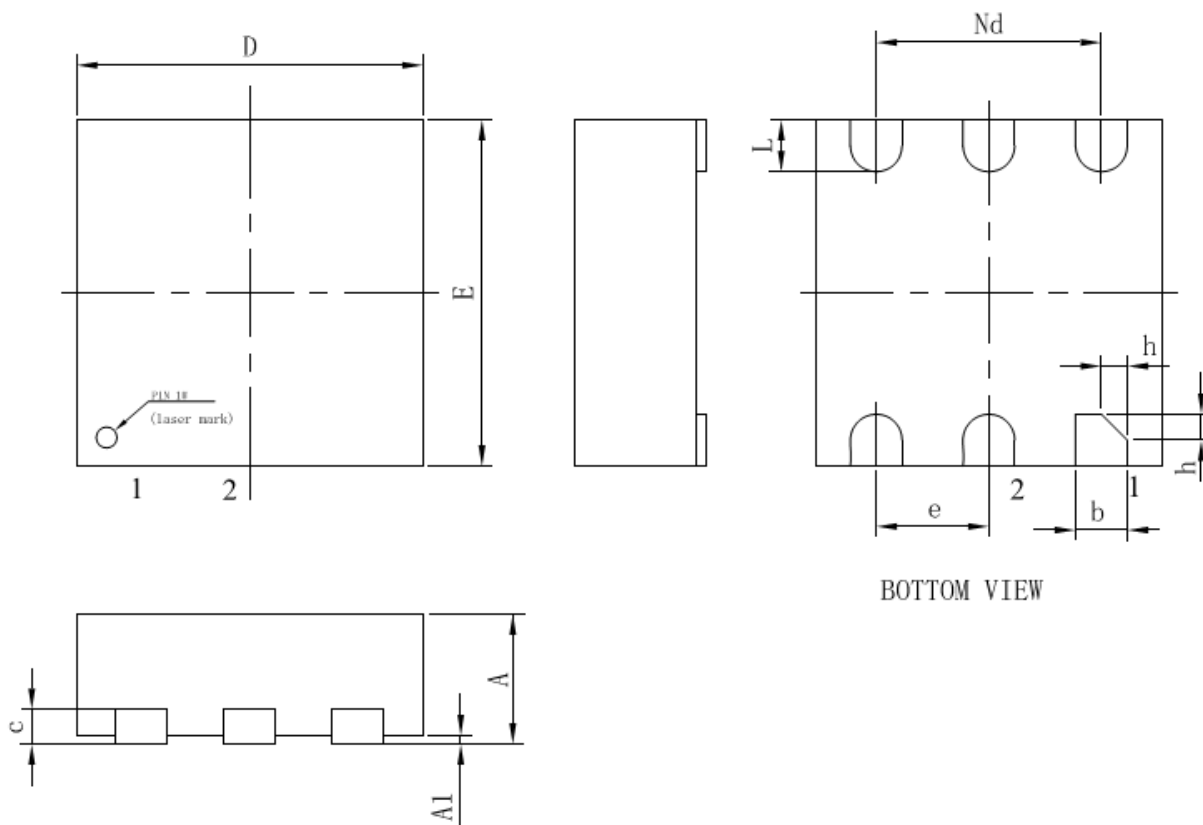

BOTTOM VIEW

Symbol	Dimensions in millimeter		
	Min.	Typ.	Max.
A	0.70	0.75	0.80
A1	0.00	0.02	0.05
D	1.95	2.00	2.05
E	1.95	2.00	2.05
b	0.25	0.30	0.35
c	0.18	0.20	0.25
e	0.65 BSC.		
Nd	1.30 BSC.		
L	0.25	0.30	0.40
h	0.10	0.15	0.20